

## SPECIFICATION

Power Supply	220 VAC $\pm$ 15%, 50/60 Hz
Load Incandescent Bulb	1000 W
Load Halogen Lamp	500 W
Load Fluorescent Lamps	200 VA
Load LED Lamp	150 W
Power Consumption	1 VA
Infrared Sensor	Detectable 360°
Delay Time	About 8 Sec-5 Min
Detecting Speed	0.1~3.0 m/sec
Operation Temperature	-10°C~60°C
Material	ABS-VO
Size (mm.)	$\varnothing$ 112
Weight	200g.

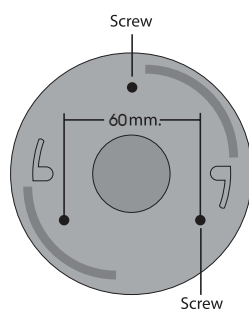
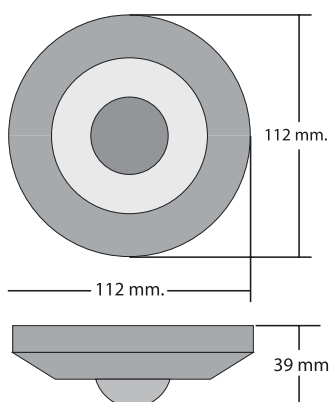

## OPERATION

MR- N SERIES installation can install at ceiling area in the building, office, residential.

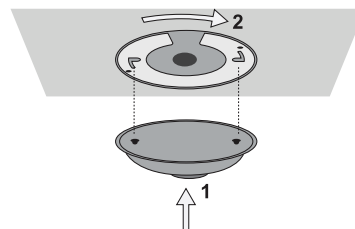

## DESCRIPTION

- MR-N SERIES is the automatic ON-OFF control for lighting inside building, office etc.
- Can detect light intensity and movement.
- Can detect 360°
- Can delay the operation 8 Sec - 5 Min.
- Suite to install on room ceiling.

## OPERATION

MR-SERIES is the device controls automatic ON-OFF lighting inside building, office, residence etc. User can choose automatic switch when light volume less than doesn't enough from setting and delay time to turn on light since 8 Sec - 5Min. Detection degree is 360° with small and compact size. Easy to install by designed for suitable installing on ceiling.

**MR-01N** : can control turn on - off automatically by use the light illuminate detection when light has less more than setting value it will make switch "ON".

**MR-02N** : can control turn on - off automatically by use the light illuminate and movement detection when light has less more than setting value and has movement it will made switch "ON". It will save energy and cost that may increase from turn the light on all the time.

**MR-03N** : can control turn on - off automatically by use the light illuminate and movement detection. The movement will make switch "ON". it will save energy and cost that may increase from turn the light all the time.

## WIRING DIAGRAM

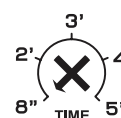
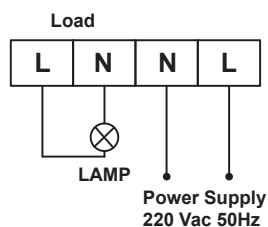

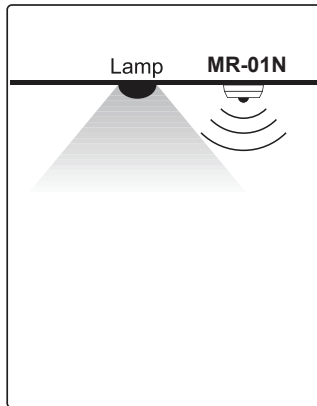
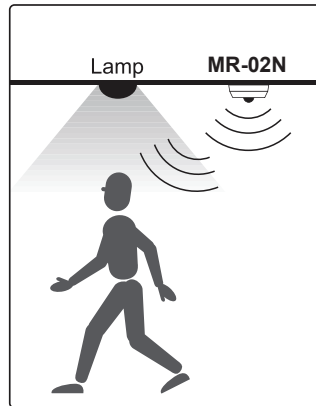
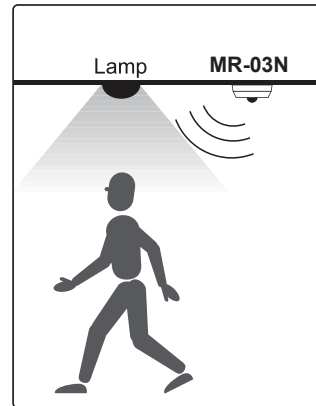
**DETECTION FORM**
**MR-01N** Light Sensor

**MR-02N** Light & Motion Sensor

**MR-03N** Motion Sensor

Detection Range	2m
Coverage (Diameter)	3m
Detection angle	360°

**ORDER CODE**

MR-

01N	Light Sensor
02N	Motion & Light Sensor
03N	Motion Sensor



MR-N-Series

**บริษัท ไพรมัส จำกัด**  
 119 ซ.สีม่วงอนุสรณ์ ถ.สุทธิสารวินิจฉัย แขวงดินแดง  
 เขตดินแดง กรุงเทพฯ 10400  
 โทร 0-2693-7005, 0-2277-8027 แฟกซ์ 0-2277-3565  
 E-mail : sales@primusthai.com