



KM-20-P7



TECHNICAL SPECIFICATION

Power Supply	230 ±15% VAC 50-60 Hz	
Power Consumption	115 ±15% VAC	
Power Consumption	2.5VA	
Display	7-Segment, Size 0.56 Inch,	
Input	Volt	1 Phase
	Volt Range	20-500 VAC
	Accuracy Volt	±0.5% FS.
	Current	Connection 1 CT, Direct
	Current Transformer Ratio	1-2000
	Primary	9999 AMP
	Secondary	0.01-5A
Output	Relay Output	SPDT 5A 250VAC / 5A 30VDC
	Protocol	MODBUS RTU
Communication	Baud Rate	2400, 4800, 9600, 19200, 38400, 57600, 115200 bps
	Parity	None, Even, Odd
	Stop Bits	1, 2
	Data Bits	8 Bits
	Support Device Node	255
Ambient Operation	Temperature	-10 °C to 60 °C
	Humidity	85 % RH Non-Condensing
Ambient Storage	Temperature	-20°C to 80 °C
	Humidity	85 % RH Non-Condensing
Protection Degree	IP30	
Installation	Panel	
Material	ABS-V0	
Size	72 x 72 x 73 mm.	
Weight	280 g.	

DIMENSION

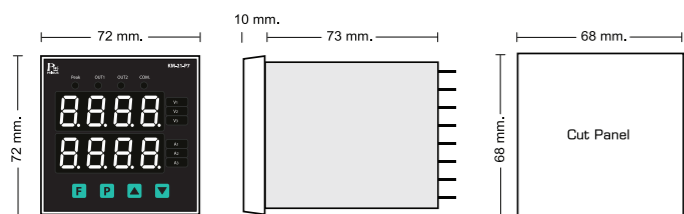

DESCRIPTION

- Single phase voltage measurement system for up to maximum 500 VAC
- Current measurement range 0.01 - 5 A, showing maximum current value 9999 A by passing C.T. Ratio Range 1 - 2000 (10000 / 5A)
- Under and Over Voltage Protection Relay
- Under and Over Current Protection Relay
- Peak Hold for Maximum of voltage, current
- Fault Display with Memory
- RS - 485 Modbus RTU
- Shows value from measure, Output and Peak.
- Manual / Auto Display Current and voltage values

OPERATION

The KM - 20 - P7 is a measurement and display device for both the voltage and current in the same phase along with Voltage Protection Relay to prevent power failure, Overload . Peak value of voltage and current can be remembered happened to analyze the feasibility of the system

Voltage Protection Relay can set the power to fall Overloaded during 20 - 500 VAC by setting delay before starting work from 1 - 3600 seconds (ON Delay Time) will capture the voltage . If the voltage is lower or higher than the value set, the Relay will order OFF within 0 - 3600 seconds, which can be set to cut fast or slow as needed and display the reason that Display when the voltage level returns to the voltage range at set Relay to return ON again within the set time (ON delaytime). After the KM-20-P7 circuit breaker or Relay OFF, can see the cause of the Relay OFF from the Display. Graph showing the operation of the Volt Protection is shown in graph 1.

Graph 1 display Voltage protection relay operation

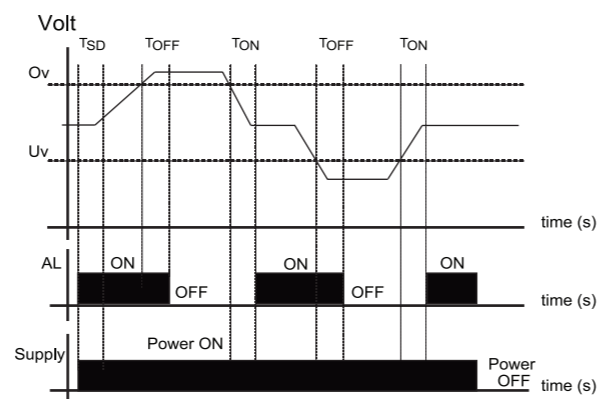

Current Protection Relay can set low current or can be between 0.1 to 9999A. Set the delay time before starting to run from 1-3600 seconds (ON delay time). When starting, it will catch the possibility of electricity. If the electricity is higher than that set, the Relay will order OFF within 0 - 3600 seconds, which can be set to cut fast or slow as needed and display the cause at Display. When the current level returns to the level below the set, Relay will return ON again within 1 - 3600 seconds

After the KM - 20 - P7 circuit breaker or Relay OFF, can see the cause of the Relay OFF from the Display or reverse function. The current protection relay operation graph is shown in graph 2.

Graph 2 display the Current protection relay operation

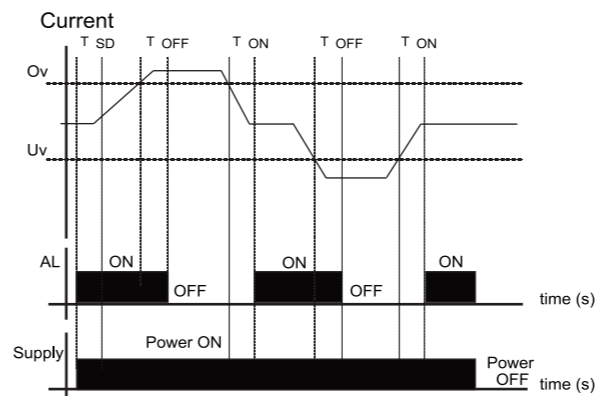

Stand-by Sequence

Function of this function will check whether the voltage or current of each phase. After the end of the Start Time period, the Output Relay will not work until the value is in the Output Relay phase. Shown as graph 3

Graph 3 shows Voltage Stand-by sequence operation

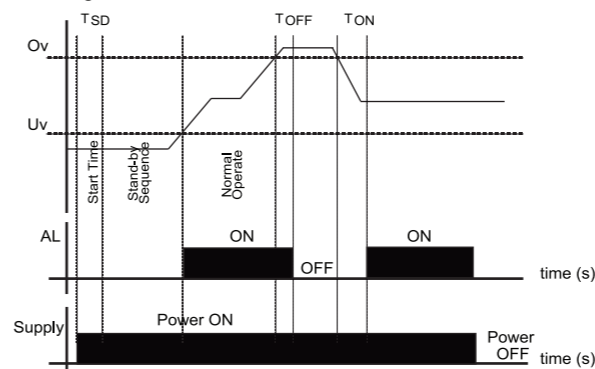

Manual and Auto Display

The display of the measured Volt, Amp values can be either Manual. click on the Volt, Amp value by pressing the key pad on the device or Auto is shown. Volt, Amp, each phase is rotated all the time, can be set to display values from 10 seconds to 60 seconds per phase. If you do not want to display Auto, you can do so by setting the time to 0.

How to Calculate value

$$\text{Volt} = \frac{\text{Volt Reg}}{10}$$

$$\text{Current} = \frac{\text{Current Reg}}{\text{Current Exponential} \cdot 10}$$

$$\text{Hz} = \frac{\text{Hz Reg}}{10}$$

WIRING DIAGRAM

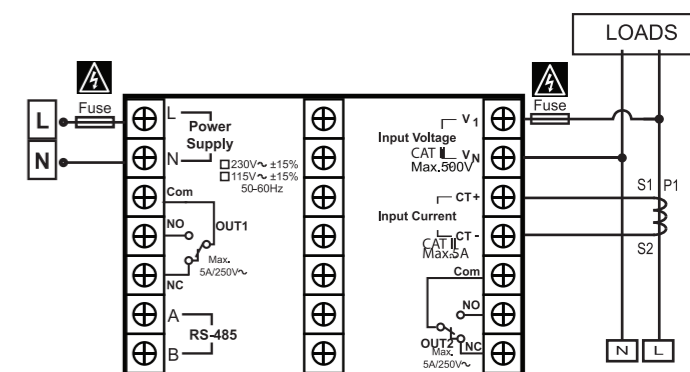

ORDERING CODE

KM-20-P7 - A -

OPTION	SUPPLY
None	None 230 VAC
B Alarm Relay 2	115 115 VAC
M RS-485	

First page



Display Volt, Current value

Display Volt, Current value



Display Volt, Current value



Display Hz Value

Displays the Previous Fault value of Protection Relay, Volt angle between Current, Hz

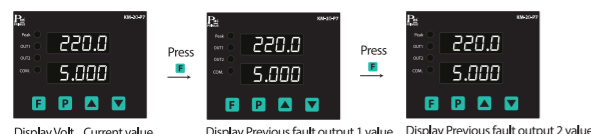

Display Volt, Current value

Display Previous fault output 1 value

Display Previous fault output 2 value

Display Peak Volt, Peak Current value



Displays Volt angle between Current

Display Peak Volt, Peak Current value

Volt Fault alert and Current of Protection Relay



Display Volt, Current value

Display Volt, Current value

CONFIGURATION

KM-21-P7

Measurement Display
0000 Show Measurement Value
Press **F** hold 2 seconds

1. CT Ratio (For KM-21)
Ct 1 CTRatio range 1 to 2000
Press **F** 1 time

2. Start Delay Time
St 003 1 to 3600 Sec
Press **F** 1 time

3. Function Setting for Output 1
OPF1 11 Select Type and Function of Alarm Relay

Type	Alarm Function
0 : Disable	0 : Over and Under limit
1 : Volt Protection	2 : Over limit
2 : Current Protection	3 : Under limit
3 : Inverse Current Protection	

Press **F** 1 time

4. Stand-by Sequence
Stb1 OFF OFF : Disable
ON : Enable
Press **F** 1 time

5. Over limit setting for Output 1
SPH1 250 Volt Protection : 50.0 to 500.0V
Current Protection : 0.1 to 999.0 A
Press **F** 1 time

6. Under limit setting for Output 1
SPL1 190 Volt Protection : 50.0 to 500.0V
Current Protection : 0.1 to 999.0 A
Press **F** 1 time

7. ON Delay Time setting for Output 1
Ond1 3 1 to 3600 Sec
Press **F** 1 time

8. OFF Delay Time setting for Output 1
OFd1 3 0 to 3600 Sec
Press **F** 1 time

9. Function Setting for Output 2
OPF2 11 Select Type and Function of Alarm Relay

Type	Alarm Function
0 : Disable	0 : Over and Under limit
1 : Volt Protection	2 : Over limit
2 : Current Protection	3 : Under limit
3 : Inverse Current Protection	

Press **F** 1 time

10. Stand-by Sequence 2
Stb2 OFF OFF : Disable
ON : Enable
Press **F** 1 time

11. Over limit setting for Output 2
SPH2 5.0 Volt Protection : 50 to 500V
Current Protection : 0.1 to 9999 A
Press **F** 1 time

12. Under limit setting for Output 2
SPL2 0.1 Volt Protection : 50.0 to 500.0V
Current Protection : 0.1 to 999.0A
Press **F** 1 time

13. ON Delay Time setting for Output 2
Ond2 3 1 to 3600 Sec
Press **F** 1 time

14. OFF Delay Time setting for Output 2
OFd2 3 0 to 3600 Sec
Press **F** 1 time

15. Clear Peak Volt, Current
CL-P -CLR --- : Disable
-CLR : Enable
Press **F** 1 time

16. Clear Previous Fault
CL-F -CLR --- : Disable
-CLR : Enable
Press **F** 1 time

17. RS-485 Address
Addr 1 Setting Device Address 1 to 255
Press **F** 1 time

18. RS-485 Baud Rate
bAud 9600 Baud rate
2400 bps 19200 bps 115200 bps
4800 bps 38400 bps
9600 bps 57600 bps
Press **F** 1 time

19. Communication Stop bit/Parity bit
Com n15 N15 : none parity, 1 stop bit
e15 : even parity, 1 stop bit
o15 : odd parity, 1 stop bit
n25 : none parity, 2 stop bit
e25 : even parity, 2 stop bit
o25 : odd parity, 2 stop bit
Press **F** 1 time

20. Auto Display
Aut 0 Set the time 10 to 60 seconds for changing showing the Volt and Amp values that are measured in order If set to 0: Disable
Press **F** 1 time

Table 1

Symbol	Display	Comment
0	----	None
1	0uu	Over Volt
2	Unu	Under Volt
3	0uL	Over Current
4	UnC	Under Current

SERIAL COMMUNICATION

The KM - 20 are Equipped With a RS - 485 Series Communication Interface to Allow Connection to Computer or PLCs. MODBUS PROTOCOL is Provided as Standard Communication. The User Can Connect KM - 20 as Network Up to 128 Meters.

Wiring Diagram

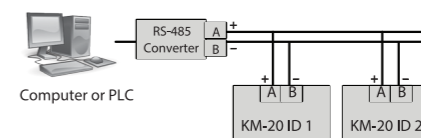

MODBUS PROTOCOL

This MODBUS PROTOCOL Has Been Implement In Accordance With MODBUS.ORG MODBUS Application PROTOCOL Specification V1.1 With The Following Conditions Applying. The Following Conditions Apply Baudrate Can Selected Refer 22. Speed Setting The Format Is MODBUS RTU Refer 22. Speed Setting The Format Is MODBUS RTU UART Data Can Selected Refer 23. Communication Setting Data Is Considered To Be Half Duplex Using 2 Wire.

Modbus Function code

Function code	Operation	Broadcast
0x03	Read Holding Registers	No
0x04	Read Multiple Registers	No
0x06	Preset Single Registers	Yes
0x10	Preset Multiple Registers	Yes

Example of a client request and server exception response

Request	Response
Field Name (Hex)	Field Name (Hex)
Slave Address 01	Slave Address 01
Function 04	Function 84
Starting Address Hi 00	Exception Code 02
Starting Address Lo 00	CRC Hi C2
Quantity of Input Reg. Hi 00	CRC Lo C1
Quantity of Input Reg. Lo 1E	
CRC Hi 70	
CRC Lo 02	

Modbus Exception code

Code	Name	Meaning
01	ILLEGAL FUNCTION	The function code received in the query is not an allowable action for the server (or slave).
02	ILLEGAL DATA ADDRESS	The data address received in the data field is not an allowable value for server (or slave).
03	ILLEGAL DATA VALUE	A value contained in the query data field is not an allowable value for server (or slave).

MODBUS table of KM - 20 as shown in the following table

Modbus Table 1

Reg. Address	Decimal	Hex	Contents	Format	Word	Access	Comment
0	0x0	0x0	Volt	Unsignde int	1	Read Only	
1	0x1	0x1	Current	Unsignde int	1	Read Only	
2	0x2	0x2	Current Exponential	Unsignde int	1	Read Only	
3	0x3	0x3	Hz	Unsignde int	1	Read Only	
4	0x4	0x4	Peak Volt	Unsignde int	1	Read Only	
5	0x5	0x5	Peak Current	Unsignde int	1	Read Only	
6	0x6	0x6	Peak Current Exponential	Unsignde int	1	Read Only	
7	0x7	0x7	Previous Fault Alarm 1	Unsignde int	1	Read Only	
8	0x8	0x8	Previous Fault Alarm 2	Unsignde int	1	Read Only	

Modbus Table 2

Reg. Address	Decimal	Hex	Contents	Format	Word	Access	Comment
256	0x100	0x100	CT Ratio	Unsignde int	1	R/W	
257	0x101	0x101	Start Time	Unsignde int	1	R/W	1-3600
258	0x102	0x102	On Delay 1 Time	Unsignde int	1	R/W	1-3600
259	0x103	0x103	Off Delay 1 Time	Unsignde int	1	R/W	0-3600
260	0x104	0x104	Function Alarm 1	Unsignde int	1	R/W	
261	0x105	0x105	Stand-by Sequence 1	Unsignde int	1	R/W	
262	0x106	0x106	On Delay 2 Time	Unsignde int	1	R/W	1-3600
263	0x107	0x107	Off Delay 2 Time	Unsignde int	1	R/W	0-3600
264	0x108	0x108	Function Alarm 2	Unsignde int	1	R/W	
265	0x109	0x109	Stand-by Sequence 2	Unsignde int	1	R/W	
266	0x10A	0x10A	Over Limit Alarm 1	Unsignde int	1	R/W	Volt : 50-500 Current : 1-9999
267	0x10B	0x10B	Under Limit Alarm 1	Unsignde int	1	R/W	Volt : 50-500 Current : 1-9999
268	0x10C	0x10C	Over Limit Alarm 2	Unsignde int	1	R/W	Volt : 50-500 Current : 1-9999
269	0x10D	0x10D	Under Limit Alarm 2	Unsignde int	1	R/W	Volt : 50-500 Current : 1-9999

Manual Reset Protection Relay

Press **F** hold 5 seconds start Time will start again. Start Time is used to delay the detection of Volt, Current during this time, LED Out1, Out2 will flash until the end of the Start Time and check Volt, Current In the case that one of the output functions is Disable Output, the function will not work during the Start Time period. LED Out1, Out2 will not flash.

How to Reset Peak Volt, Current

1. Set parameter CL-P to become -CLR
2. Must be on page display peak results on any one page and press button **F** + **F** hold 5 seconds
3. When Reset parameter value CL-P to become ----

How to Reset Fault Alarm

1. Set parameter CL-F to become -CLR
2. Must be on page display Fault alarm on any one page and press button **F** + **F** hold 5 seconds
3. When Reset parameter value CL-F to become ----