



CMP-48N

DIGITAL PRESET COUNTER



TECHNICAL SPECIFICATION

Power Supply	220 VAC ±15% 50/60 Hz 24 VAC/VDC ±15%	
Power Consumption	3VA	
Display	7 Segment, 4 Digit, Size 0.56 Inch, 2 Rows	
Input	Range Display and Setting	Measurement Range -1999 to 9999
	Input Frequency	0 to 10 kHz
	Input Type	Photo Switch, Proximity, Contact, Encoder, NPN, PNP
	DC Source for Sensor	24 VDC 100 mA
	Decimal Point Setting	0 to 0.000
	Timer (Input Filter)	0.00 to 10.00 Sec
	Timer Accuracy	±10 ms
Output	Relay Output	2 Relay Output 5A/250VAC
	Protocol	MODBUS RTU
Communication	Baud Rate	4800, 9600, 19200, 38400, 57600 bps
	Parity	None, Even, Odd
	Stop Bits	1, 2
	Data Bits	8 Bits
	Address	1 - 255
Ambient Operation	Temperature	-10 °C to 60 °C
	Humidity	85 % RH Non-Condensing
Ambient Storage	Temperature	-20 °C to 80 °C
	Humidity	85 % RH Non-Condensing
Protection Degree	Front Protection Rating	IP52
	Case Protection Rating	IP30
Installation	Panel Mounting	
Material	ABS-V0	
Size (mm.)	48 x 48 x 80 mm	
Weight	148 g.	

DESCRIPTION

- Digital Counting Machine
- 7-segment display
- Get input from sensor devices such as Photo Switch, Proximity Switch, Encoder, Contact, NPN, PNP
- Available operating modes: 7 operating modes
- Can operate in count up and count down
- EEPROM memory keeps counts in case of power failure.
- Can set the count sensitivity.
- Easy to use program through screen.
- Can communicate with computer through RS485 port, MODBUS RTU

OPERATION

Digital display devices displaying results with 7-Segment in Real Time format, receiving input from. Various sensor devices such as Proximity Switch, Encoder, Mechanical Contact, NPN, PNP. It can accept input as fast as 10kHz. 11 operating modes are available. with FRAM can link with Computer or PLC Logging, Edit values via RS485 and can monitor.

WIRING DIAGRAM

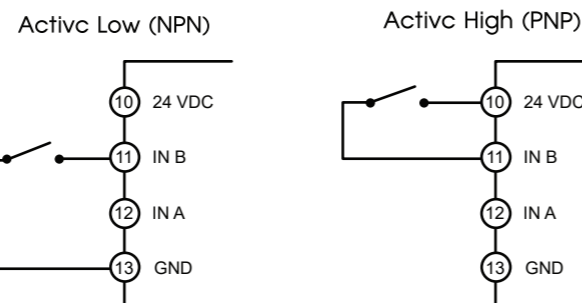
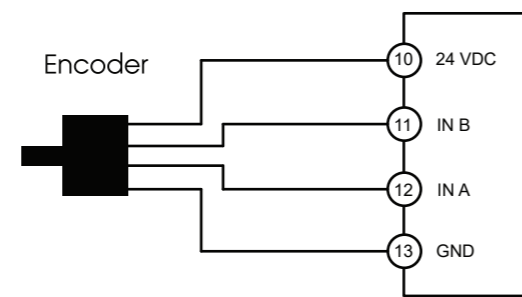
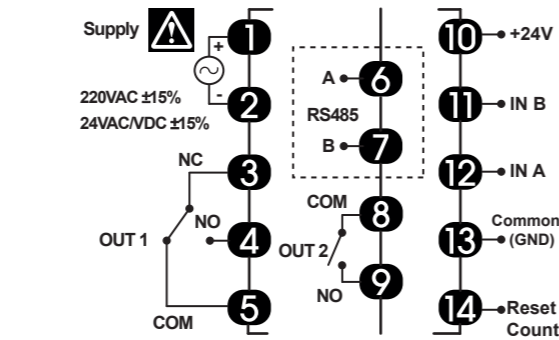

WARNING

- Make sure the correct wiring connection before turning on electricity. Mis-wiring may cause malfunction of the unit and fire.
- Never modify the unit to prevent damage or incident such as malfunction and fire etc.

FUNCTION OUTPUT MODE

*Count Reset Value is Count after Reset

MODE 1

- When count up or count down to Set Point 1 from setting. It will made OUT 1 ON until press Reset and when Count value count up or count down to Set Point 2 from setting until Reset pressing.
- OUT1 Retentive output / Count Continuation Relay ON all time even stay in condition.
- OUT2 Retentive output / Count Continuation Relay ON all time even stay in condition.

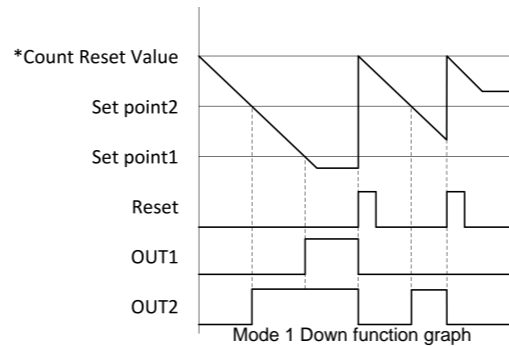
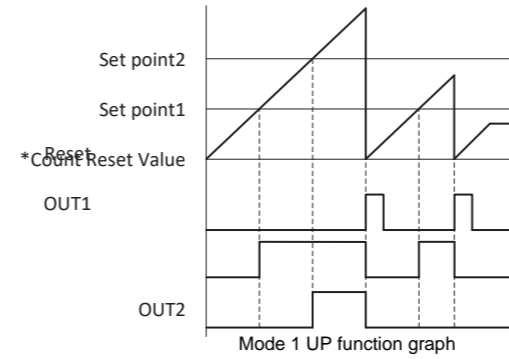

MODE 2

- When Count up or down to Set Point 1 from setting will made OUT 1 ON until press Reset and Count up or count down to Set Point 2 from setting will Reset count and OUT 2 ON follow time of One shot duration 2
- OUT1 Retentive output / Count Continuation relay ON all time when stay in condition.
- OUT2 One-Shot output / Count Resetting relay ON follow time 0.5d.2

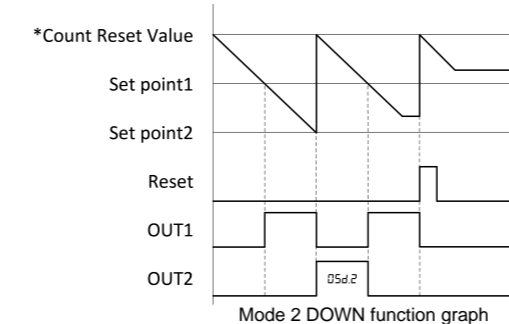
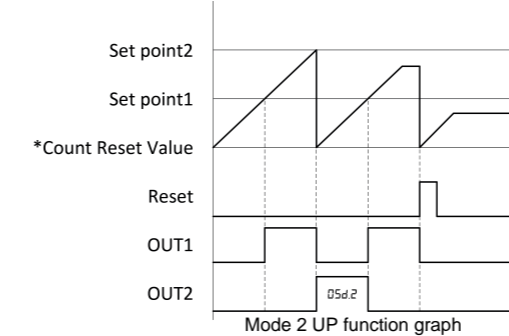

MODE 3

- When count up or count down to Set Point 1 from setting. It will made OUT 1 ON follow time of One Shot duration 1(OSD.1) and when Count value count up or count down to Set Point 2 from setting. It will made OUT 2 ON until press Reset.
- OUT1 One-Shot output / Count Continuation Relay ON follow time 0.5d.1
- OUT2 Retentive output / Count Continuation Relay ON on time when stay in condition.

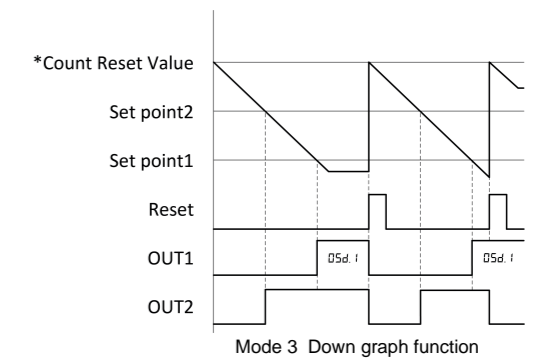
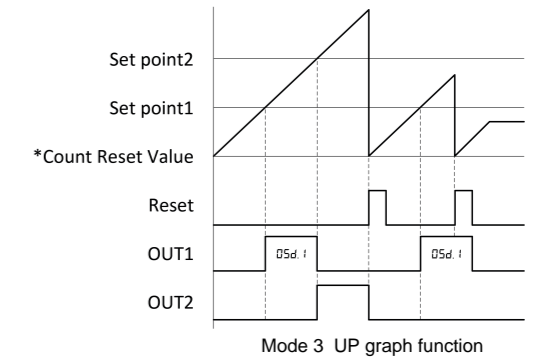

MODE 4

- When count up or count down to Set Point 1 from setting. It will made OUT 1 ON follow time of One Shot duration 1 and when Count value count up or count down to Set Point 2 from setting will Reset count and OUT2 ON follow time of One shot duration 2.
- OUT1 One-Shot output / Count Continuation Relay ON follow time 0.5d.1
- OUT2 One-Shot output / Count Resetting Relay ON follow time 0.5d.2

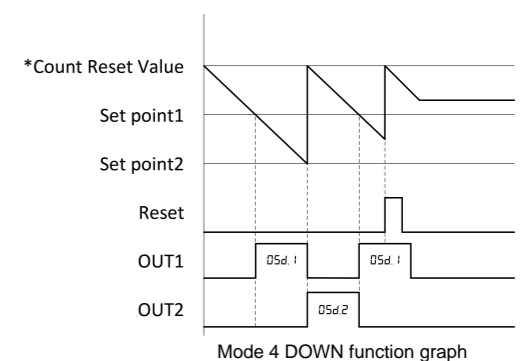
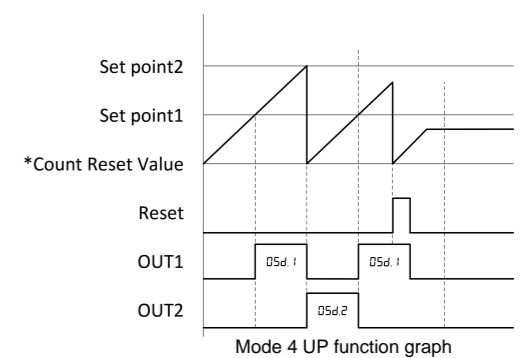

DIMENSION CUTTING AND INSTALLATION

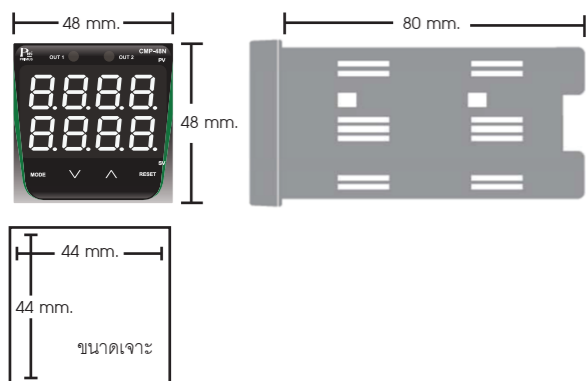

MODE 5

When Count value more or equal to Set Point 1 from setting will made OUT 1 ON until Count value less than Set Point 1 will made OUT 1 OFF and when Count value more than Set Point 2 will made OUT2 OFF until Count value less or equal to Set Point 2 will made OUT2 ON

- OUT1 Count Value \geq Set point 1
- OUT2 Count Value \leq Set point 2

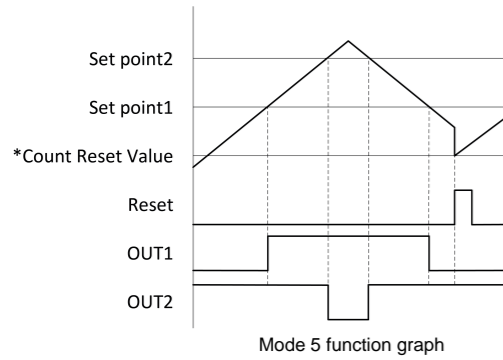

MODE 6

When Count more or equal to Set Point 1 from setting. It will made OUT 1 ON until Count less Set Point 1 will made OUT 1 OFF and when Count more or equal to Set Point2 ON until Count less than Set Point 2 will made OUT 2 OFF.

- OUT1 Count Value \geq Set point 1
- OUT2 Count Value \geq Set point 2

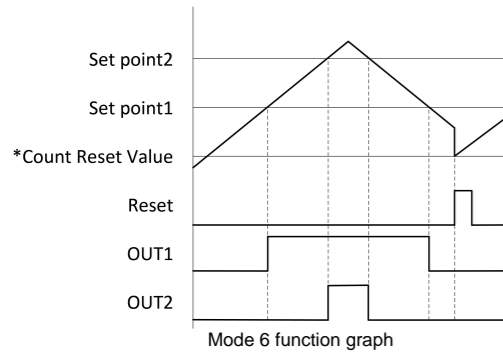

MODE 7

When Count less than Set Point 1 from setting. It will made OUT 1 ON until Count more or equal to Set Point 1 will made OUT 1 OFF and OUT 2 ON when Count more than Set Point 2 will made OUT 2 OFF.

- OUT1 Count Value < Set point 1
- OUT2 Count Value \geq Set point 1 and Count Value \leq Set point 2

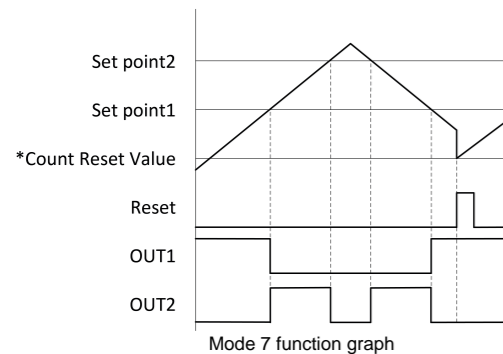

DIRECTION INPUT MODE

MODE UP

Count the rising edge will count Count Value value immediately when Input come.

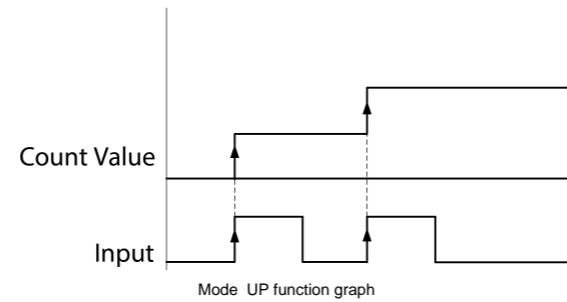

MODE DOWN

Count the down edge will count Count Value value immediately when Input come and go.

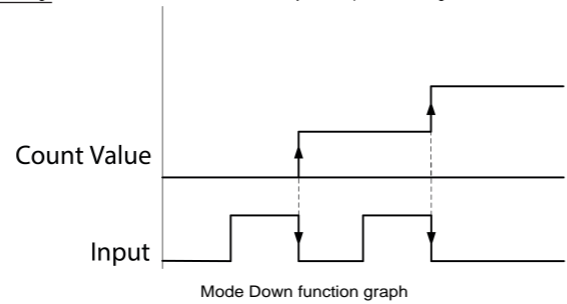

PRESCALING

We can scale pulse value that come by setting count multiplier such as request count up to pulse and 0.7 so scale in form divisor.
scale = multiplier/divisor, scale = 0.7 = 7/10.
∴ so multiplier = 7, divisor = 10



Calculation When Input come in at n Pulse
Count = (n * multiplier) / (n * divisor)

EXAMPLE

1. Encoder wheel type 100 pulse/round when run complete 1 round will have 0.45 metre. User needs to show in metre unit decimal 2 position.

Calculation
Display value = Pulse from actual counted * Scale
0.45 = 100 * Scale = multiplier/Divisor
Multiplier (multiplier) = 45, Divisor (divisor) = 10000, 45/10000
make multiplier, divisor to be simplest form 45/10000 = 9/2000

Setting
Multiplier (multiplier) = 9, divisor (divisor) = 2000
Decimal (d.P) = 0.00
Input (Input) = Encoder

2. Production line install Sensor NPN type count product to pack in the boxes. 12 pcs. per box by display quantity of boxes.

Calculation
Display = Pulse from actual counted * Scale.
1 = 12 * Scale = multiplier/divisor
Multiplier (multiplier) = 1, divisor (divisor) = 12, 1/12
Setting
Multiplier (multiplier) = 1, divisor (divisor) = 12
Decimal (d.P) = 0
Input (Input) = H 15Pd

SERIAL COMMUNICATION

The CMP series are equipped with a RS485 serial communications interface to allow connection to computer or PLC. MODBUS protocol is provided as standard communication. The user can connect CMP series as network up to 255 meters.

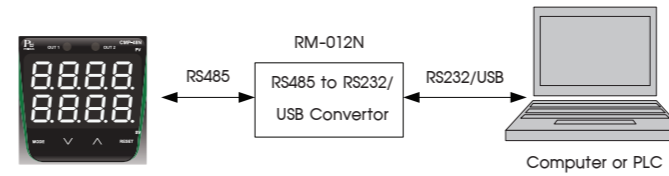

MODBUS PROTOCOL

This MODBUS Protocol has been implement in accordance with MODBUS.ORG MODBUS Application Protocol Specification V1.1 With the following conditions applying

The following conditions apply
Baudrate must be set for 4800, 9600, 19200, 38400, 57600 bps
The format is MODBUS RTU
UART data 8 bites, 1 stop bit and no parity
Data is considered to be half duplex using 2 wire.

Exception Responses

The following exception codes will be supported only.

- 01 Illegal function
- 02 Illegal data address
- 03 Illegal value

How to calculate Register

$$\begin{aligned} \text{Count} &= \frac{\text{Count REG}}{10^{\text{Decimal Point REG}}} \\ &= \frac{1000}{10^1} \\ &= 100.0 \end{aligned} \quad \begin{aligned} \text{Total} &= \frac{\text{Total REG}}{10^{\text{Decimal Point REG}}} \\ &= \frac{32000}{10^3} \\ &= 32.000 \end{aligned}$$

Ex.1 If needs set Time Setting at 5 seconds

$$\begin{aligned} \text{Time Setting} &= \frac{5 \text{ seconds} \times 1000 \text{ ms}}{10} \\ \therefore \text{Set Time Setting REG} &= 500 \end{aligned}$$

Ex.2 If needs set OSD at 10 seconds

$$\begin{aligned} \text{One Shot Duration} &= \frac{10 \text{ วินาที} \times 1000 \text{ ms}}{10} \\ \therefore \text{Set OSD REG} &= 1000 \end{aligned}$$

Ex.3 If needs to calculate OSD time from setting

$$\begin{aligned} \text{One Shot Duration} &= \text{OSD REG} \times 10 \\ &= 20 \times 10 \\ &= 200 \text{ ms} \end{aligned}$$

***Relay Status**

- Out 1 = 1
- Out 2 = 2
- Out 3 = 4
- Ex. Out 1 ON, Out 2 ON = 1+2 = 3

MODBUS DATA REGISTER

Register	Register Name	Access	Format	Min	Max
0	Count	R/W	Long AB CD	-1999	9999
1					
2	Total		Not USE		
3					
4	Input Mode	R/W	Integer	0	2
5	Encoder Direction	R/W	Integer	0	1
6	Input Type	R/W	Integer	0	1
7	Direction Input Mode	R/W	Integer	0	1
8	Timer Mode	R/W	Integer	0	1
9	Time Setting	R/W	Integer	0	1000
10	Operate Mode	R/W	Integer	0	4
11	Decimal Point	R/W	Integer	0	3
12	Count Multiplier	R/W	Long AB CD	1	9999
13					
14	Count Divisor	R/W	Long AB CD	1	9999
15					
16	Count Reset	R/W	Long AB CD	-1999	9999
17					
18	Total Multiplier		Not USE		
19					
20	Total Divisor		Not USE		
21					
22	Total Reset		Not USE		
23					
24	Button Reset	R/W	Integer	0	1
25	Output Mode	R/W	Integer	0	11
26	Output Total Mode		Not USE		
27	Setpoint 1	R/W	Long AB CD	-1999	9999
28					
29	Setpoint 2	R/W	Long AB CD	-1999	9999
30					
31	Total Setpoint		Not USE		
32					
33	One Shot Duration 1	R/W	Integer	1	1000
34	One Shot Duration 2	R/W	Integer	1	1000
35	Total One Shot Duration		Not USE		
36	Relay Status*	R	Integer	0	3
37	Slave Address	R/W	Integer	1	255
38	Baud rate	R/W	Integer	0	4
39	Communication	R/W	Integer	0	5
40	Lock	R/W	Integer	0	1

***Relay Status**

- Out 1 = 1
- Out 2 = 2
- Ex. Out 1 ON, Out 2 ON = 1 + 2 = 3

การตั้งค่าพารามิเตอร์ CMP-48N

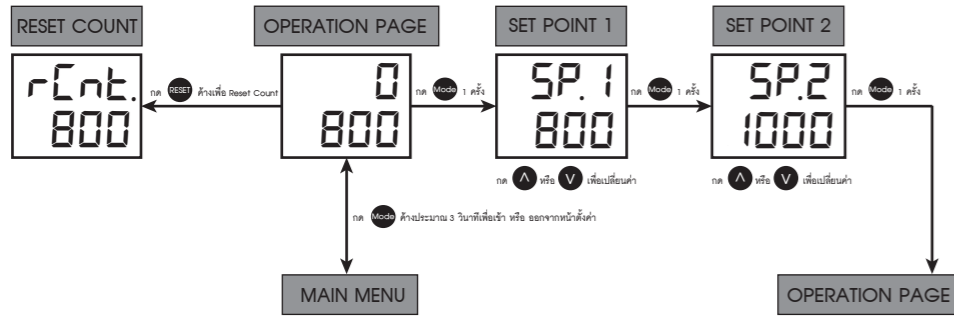

MAIN MENU

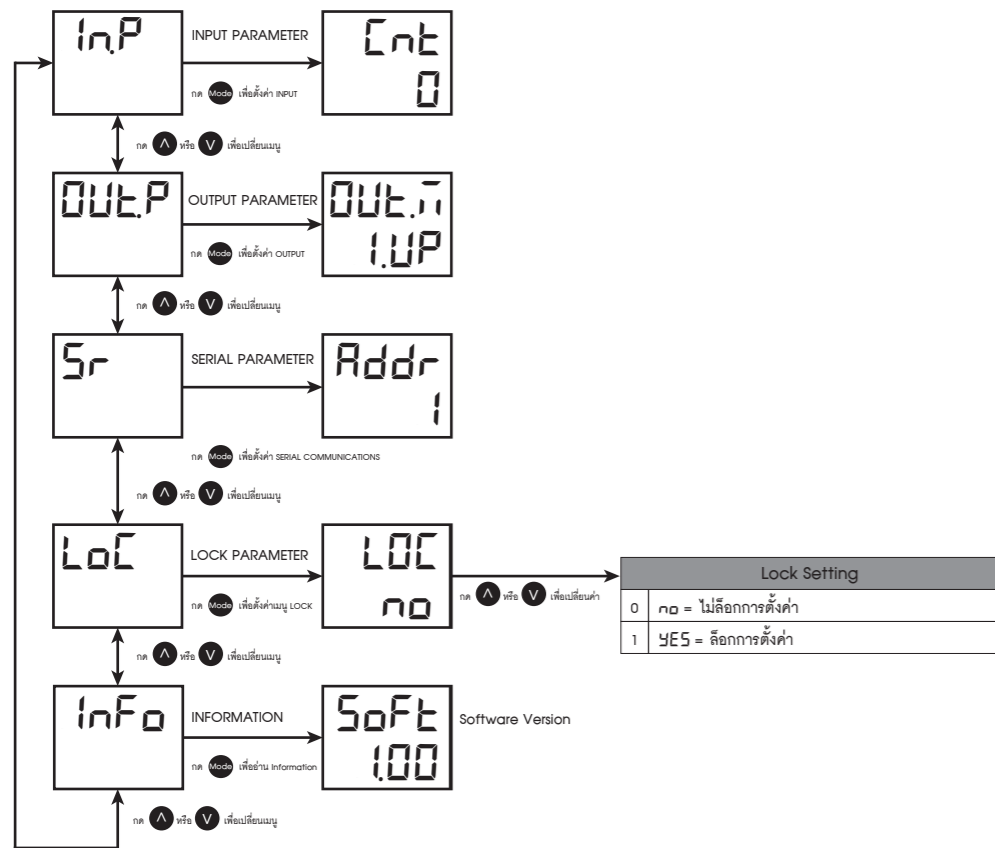

SERIAL PARAMETER

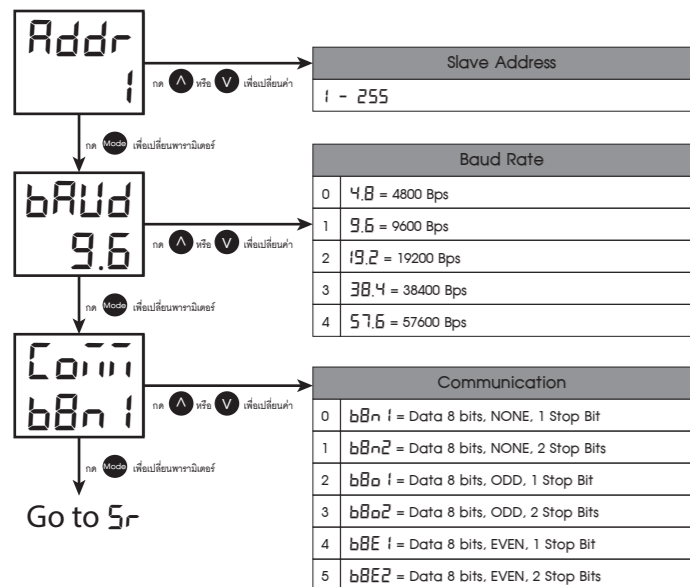

INPUT PARAMETER

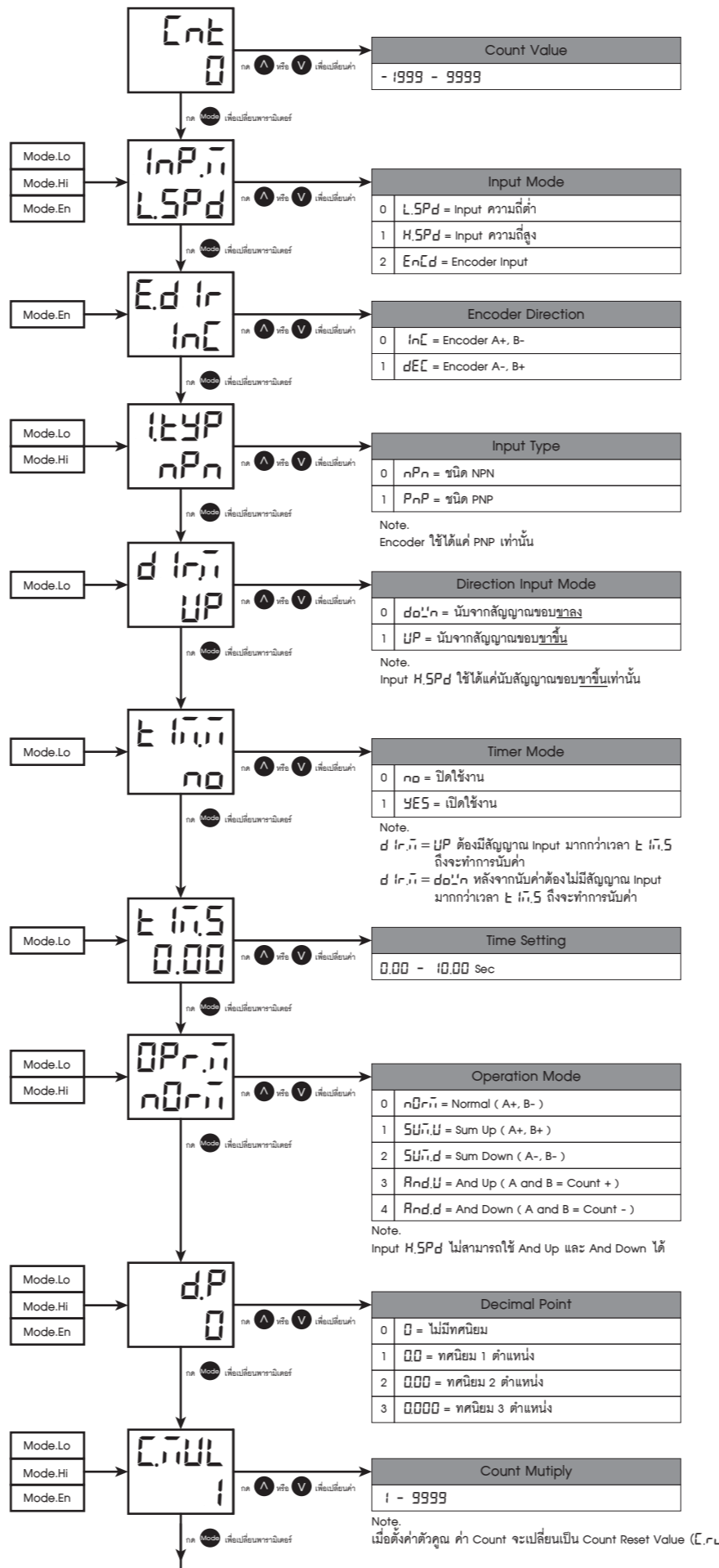

OUTPUT PARAMETER

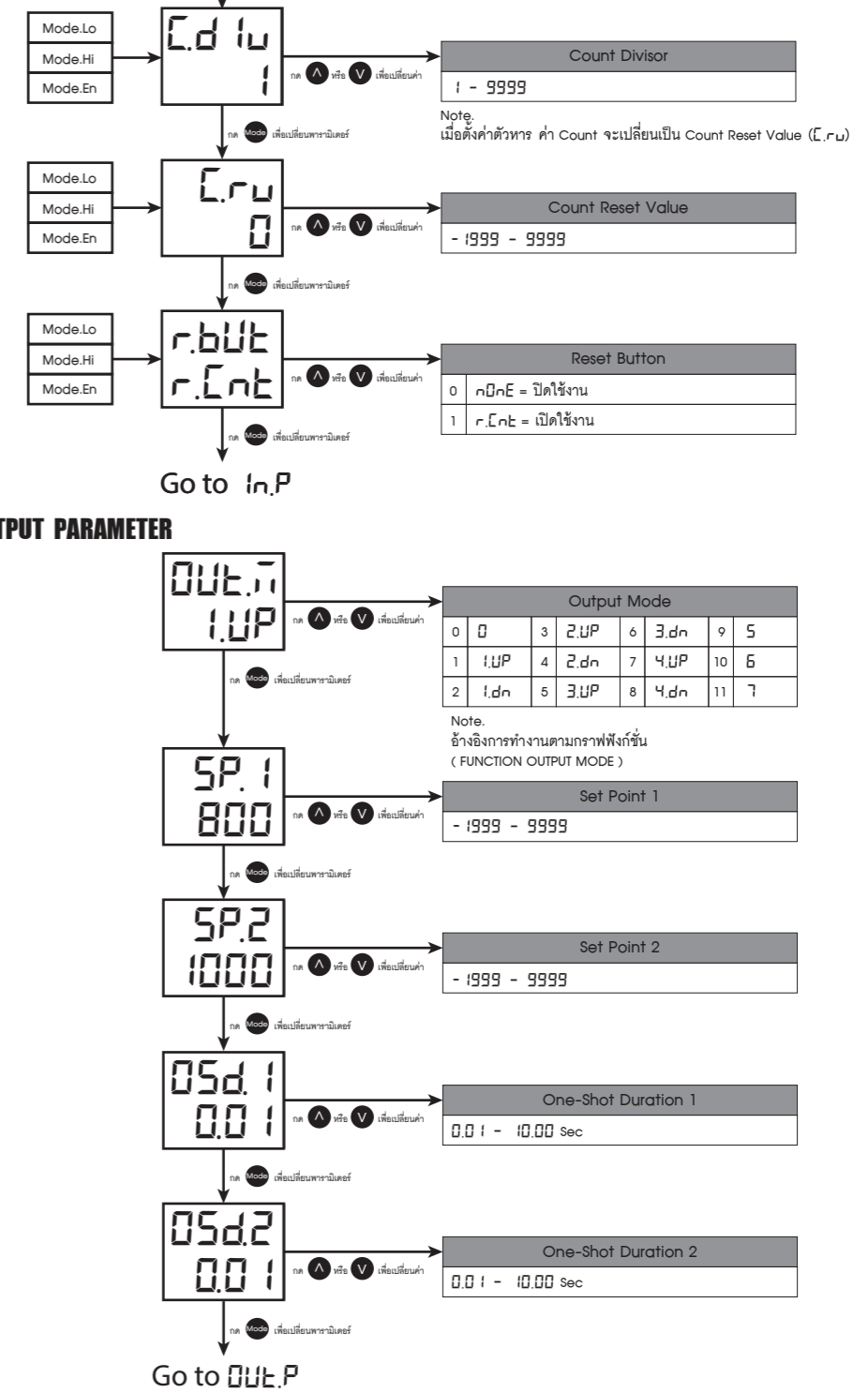

ORDERING CODE

CMP - 48N - [] - [] - []

OUTPUT	OPTION	SUPPLY
R 1 Relay Output	NONE NONE	220 220 VAC ±15%
RR 2 Relay Output	M RS485	24 24 VAC/VDC ±15%



Primus บริษัท ไพรมัส จำกัด
 119 ซ.สีม่วงอนุสรณ์ ถ.สุทธิสารวินิจฉัย แขวงดินแดง เขตดินแดง กรุงเทพฯ 10400
 โทร 0-2693-7005, 0-2277-8027 แฟกซ์ 0-2277-3565
 E-mail : sales@primusthai.com