

**DESCRIPTION**

- Paddle switch detect solid object such as rice with peel, seed, cereals etc.
- Power supply 220VAC/50-60Hz.
- Output Relay Contact 5A 250VAC.
- Thread installation LM-001N : dimension  $\varnothing$  25 mm. (3/4 inches). and LM-002/LM-002-S : dimension  $\varnothing$  47 mm.
- Operation temperature -10 to 60 °C

**OPERATION**

LM-Series is paddle switch to detect solid object that pack in silo tank such as rice with peel, rice, cereals, powder etc. for checking or controlling object level to be in required level by install on top or side of silo tank.

When supply voltage LM-Series will start operation, the paddle will rotate in round speed 0.8 RPM at 50 Hz in normal condition but when solid object add in silo tank to the level that at LM-Series install area. The paddle will stop rotate made Relay Output operate by use Contact from Relay Output connect to apply with other products such as PLC, Relay Module and control device for control level of object in silo.

**APPLICATION**

- LM-001,LM-001-1, LM-001-S suitable with Light Load application such as Hopper plastic beads of plastic injection machine.
- LM-002,LM-002-S are suitable with Heavy Duty such as silo tank in mill.

**Specification**

Model		LM-001N	LM-001N-1	LM-001N-S	LM-002	LM-002-S
Power Supply		220VAC/50-60Hz			220VAC/50Hz	
Power Consumption		1.5VA			2 VA	
Speed Round		0.8RPM 50Hz			0.8RPM 50Hz	
		1.0RPM 60Hz				
Core length	Standard	100	200	164	150	
	Special Max	500	500	500	1000	
Thread		$\varnothing$ 25 mm.	$\varnothing$ 25 mm.	$\varnothing$ 25 mm.	$\varnothing$ 47 mm.	
Output	1 Output	Relay Contact 5A 250VAC				
Ambient operation	Temperature	-10 °C to 60 °C				
	Humidity	85 % RH Non-Condensing				
Ambient storage	Temperature	-20 °C to 80 °C				
	Humidity	85 % RH Non-Condensing				
Protection Degree	Front Protection rating	IP52				
	Case Protection rating	IP30				
Installation		Screw				
Material	Housing	Aluminium and Stainless				
	Filter Head	Plastic			Aluminium	
Size		180.50 x $\varnothing$ 95.60mm.	280.50 x $\varnothing$ 95.60mm.	244.60 x $\varnothing$ 95.60mm.	220 x 160mm.	
Weigth		750g.			1485.6g.	

**Wiring Diagram**

LM-001N, LM-001N-1, LM-001N-S

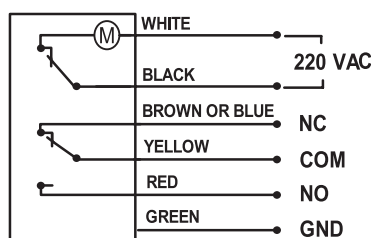

LM-002/LM-002-S

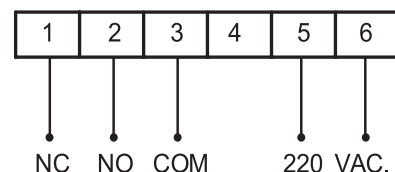

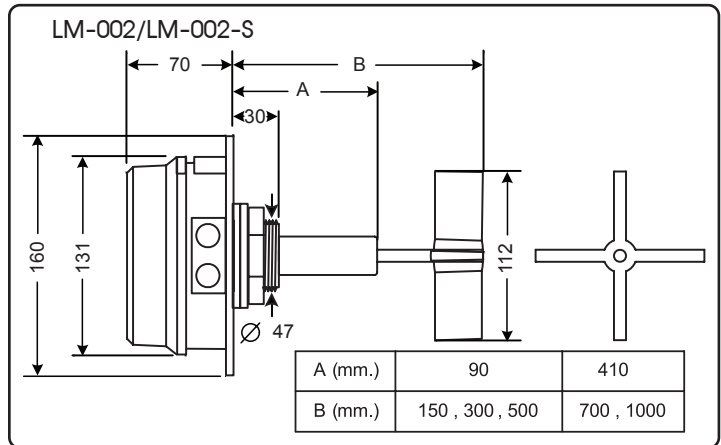
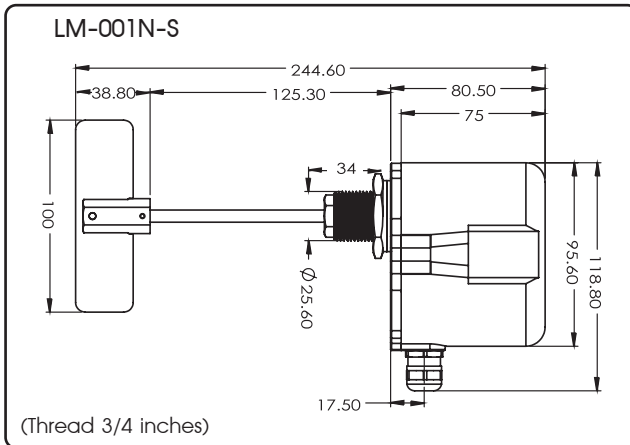
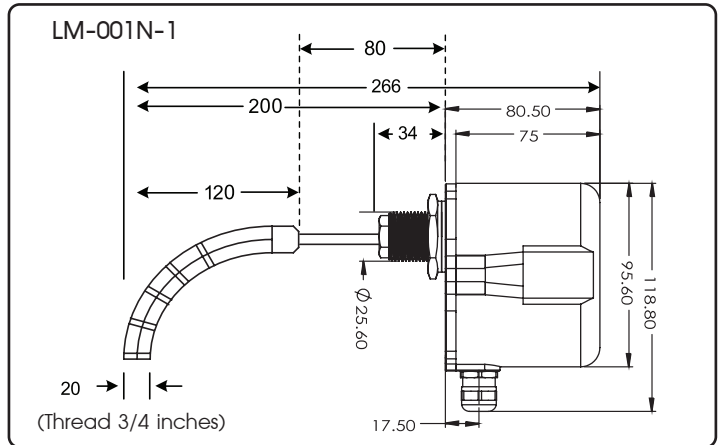
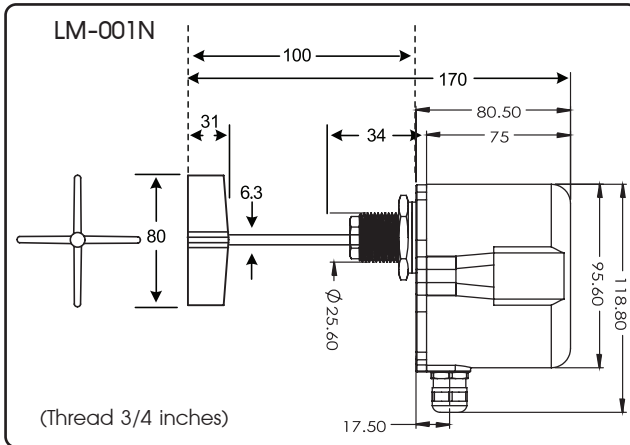
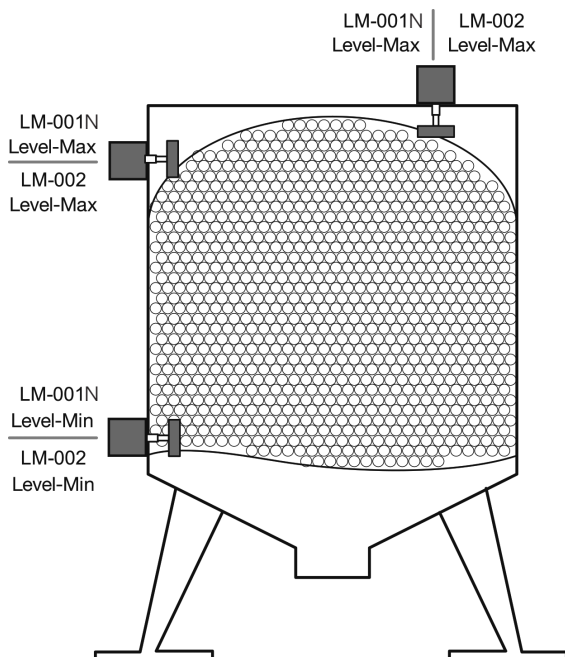
**DIMENSION**

**INSTALLATION**
**ORDERING CODE**

LM -

Paddle Type	
001N	Plastic Paddle
001N-1	Plastic Tentacle Paddle
001N-S	Stainless Paddle
002	Aluminium Paddle
002-S	Stainless Paddle

Tube and Paddle Length	
100 mm.	100 mm.
200 mm.	200 mm.
300 mm.	300 mm.
Up to 1000 mm.	Maximum 1000 mm.

**\*\*\* Standard tube and paddle length**

- LM-001N Standard tube and paddle length 100 mm. can order maximum 500 mm.
- LM-001N-1 Standard tube and paddle length 200 mm. can order maximum 500 mm.
- LM-001N-S Standard tube and paddle length 124 mm. can order maximum 500 mm.
- LM-002 Standard tube and paddle length 150 mm. can order maximum 500 mm.
- LM-002-S Standard tube and paddle length 150 mm. can order maximum 1000 mm.