

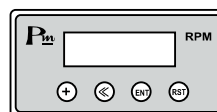

DESCRIPTION

- Box size 48 x 96 x80
- Display with 7 segment numbers, 0.56 inch red, 4 digits
- The rear connector is a screw type
- Top of the machine will have a connection diagram
- Front is well sealed. Can prevent dust and water

FRONT SHAPE AND BUTTON FUNCTION



- RST Reset Button
- ENT Enter and Set Button
- + Adjust Value Setting Button
- -> Readjust Desired Value Setting Button

APPLICATION

- Measurement Motor and Machine

DIMENSION

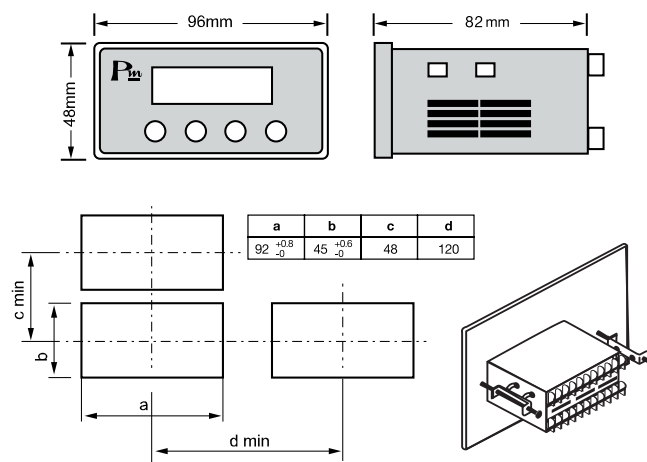

ORDERING CODE

CM - 001 - XXX

XXX = Power Supply Voltage
220 = 220 VAC

TECHNICAL SPECIFICATION

Power Supply		220 VAC ±10% 50/60 Hz
Power Consumption		3VA
Display		7 Segment 4 Digit, Size 0.56 Inch
Input	Measurement Range	
	6 to 9999 (RPM)	
	Accuracy ± 0.5% of Full Scale	
	Pulse Setting 1 to 199 per Round (RPM)	
Input Type Photo Switch/Proximity, NPN or PNP		
DC Source for Sensor 12 VDC/50 mA		
Ambient Operation	Temperature	-10 °C to 60 °C
	Humidity	85 % RH Non-Condensing
Ambient Storage	Temperature	-20 °C to 80 °C
	Humidity	85 % RH Non-Condensing
Protection Degree	Front Protection Rating	IP52
	Case Protection Rating	IP30
Installation		Panel Mounting
Material		ABS-V0
Size		48 x 96 x 82 mm.
Weight		274 g.

WIRING DIAGRAM

